



FINAL DRAFT MINUTES

April 18, 2024, Standards Committee Meeting

(Changes to the Agenda by the Action of the Committee shown as highlighted yellow.)

May 9, 2024

TO: Standards Committee

FROM: Scott Trammell, Secretary

RE: Minutes from the April 18, 2024, Standards Committee Meeting

The Standards Committee meeting was called to order by Mr. Pankow, Chair, at 09:03 a.m. on Thursday, April 18, 2024, which was held virtually via *Teams* (Microsoft application). The meeting was adjourned at 09:22 a.m.

The following committee members were in attendance:

Pankow, Gregory, Chairman, Director, Construction Management
Boruff, Dave, Traffic Engineering
Dave, Kumar, Pavement Engineering
Koch, Mike, District Construction, Fort Wayne District
Novak, Joseph, Construction Management
Orton, Mark, Highway Engineering
Pelz, Kurt, Construction Technical Support
Rearick, Anne, Bridge Management
Reilman, Jim, Materials and Tests
White, Peter, Bridge Engineering
Wooden, John, Contract Administration

Also, the following attendees were present:

Awwad, Nathan, INDOT
Barney, Bruce, INDOT
Blanchard, Jacob, INDOT
Coffin, Delaney, INDOT
Craig, Patrick, INDOT
Cruz, Elena, INDOT
Duncan, Thomas, FHWA
Fisher, Steve, INDOT

Hauser, Derrick, INDOT
Lamkin, Sara, INDOT
Mouser, Elizabeth, INDOT
Mueller, Bart, INDOT
Perugu, Kshitija, INDOT
Powell, Traci, INDOT
Russell, Melissa, INDOT
Shi, Runfa, INDOT

Fox, Gary A., INDOT
Galetka, Jason, INDOT
Harris, Tom, INDOT

Thornton, Donald, INDOT
Trammell, Scott, INDOT

The following items were discussed:

A. GENERAL BUSINESS

OLD BUSINESS

(No items were listed)

NEW BUSINESS

1. *Approval of the Minutes from the [March 21, 2024](#) meeting*

Mr. Pankow requested a motion to approve the Minutes from the March 21, 2024 meeting.

Motion: Mr. Novak
Second: Mr. Pelz
Ayes: 10
Nays: 0

ACTION:

PASSED AS SUBMITTED

B. CONCEPTUAL PROPOSAL

(No items were listed)

C. STANDARD SPECIFICATIONS, SPECIAL PROVISIONS, AND STANDARD DRAWINGS PROPOSAL

OLD BUSINESS

(No items were listed)

NEW BUSINESS

[Item No. 1](#) [Mr. White](#) [pg. 4](#)

Standard Drawing:
E 609-RCBA-04

REINFORCED CONCRETE BRIDGE APPROACH SECTION,
PAVEMENT LEDGE, AND BAR BENDING DETAILS

ACTION:

PASSED AS SUBMITTED

[Item No. 2](#) [Mr. Novak](#) [pg. 9](#)

Recurring Special Provision:
203-B-025

MARION COUNTY BORROW AREAS
(proposed to discontinue)

ACTION:

PASSED AS SUBMITTED

[Item No. 3](#) [Mr. White](#) [pg. 13](#)

2024 Standard Specifications:

703.06
703.08

Placing and Fastening
Basis of Payment

ACTION:

WITHDRAWN

cc: Committee Members
FHWA
ICI

FINAL DRAFT MINUTES

PROPOSAL TO STANDARDS COMMITTEE

PROBLEM(S) ENCOUNTERED: The current standard pavement ledge width of 6” can create vulnerabilities to future settlement of the RCBA relative to the bridge deck. The concrete-to-concrete bearing width is only 3 ½” after subtracting the widths of the PEJF material, so even a relatively small amount of deterioration or poor concrete consolidation can result in insufficient bearing capacity, which can lead to settlement. It has also been observed that the interface between the end of the RCBA and adjoining HMA pavement, when no terminal joint is required, can develop a slight separation that can allow water infiltration.

PROPOSED SOLUTION: Increase the standard pavement ledge width from 6” to 9” and add a detail to seal the interface between the end of the RCBA and adjoining HMA pavement when no terminal joint is required.

APPLICABLE STANDARD SPECIFICATIONS: 609 (no changes required)

APPLICABLE STANDARD DRAWING: E 609-RCBA-04

APPLICABLE DESIGN MANUAL CHAPTER: Several chapters in Section 4 contain figures that have been updated and will be published after the change to standards is approved.

APPLICABLE SECTION OF GIFE: N/A

APPLICABLE RECURRING SPECIAL PROVISION OR PLAN DETAILS: 609-B-311 & 609-B-322 (no changes required)

PAY ITEMS AFFECTED: No changes required to any pay items, including standard RCBA items.

APPLICABLE SUB-COMMITTEE ENDORSEMENT: INDOT/ASCE Structures Committee

IF APPROVED AS RECURRING SPECIAL PROVISION OR PLAN DETAILS, PROPOSED BASIS FOR USE:
Contracts containing 609 pay items.

IMPACT ANALYSIS (attach report):

Submitted By: Pete White

Title: Design Manager

Division: INDOT Bridge Engineering

Email: pewwhite@indot.in.gov

Date: March 22, 2024

IMPACT ANALYSIS REPORT CHECKLIST

Explain the business case as to why this item should be presented to the Standards Committee for approval. Answer the following questions with Yes, No or N/A.

Does this item appear in any other specification sections? No

Will approval of this item affect the Qualified Products List (QPL)? No

Will this proposal improve:

Construction costs? No

Construction time? No

Customer satisfaction? Yes

Congestion/travel time? No

Ride quality? Yes

Will this proposal reduce operational costs or maintenance effort? Yes

Will this item improve safety:

For motorists? No

For construction workers? No

Will this proposal improve quality for:

Construction procedures/processes? No

Asset preservation? Yes

Design process? No

Will this change provide the contractor more flexibility? No

Will this proposal provide clarification for the Contractor and field personnel? No

Can this item improve/reduce the number of potential change orders? No

Is this proposal needed for compliance with:

Federal or State regulations? No

AASHTO or other design code? No

Is this item editorial? No

Provide any further information as to why this proposal should be placed on the Standards Committee meeting Agenda:

REVISION TO 2024 STANDARD DRAWINGS

E 609-RCBA-04 REINFORCED CONCRETE BRIDGE APPROACH SECTION, PAVEMENT LEDGE, AND BAR BENDING DETAILS (with shown markups)

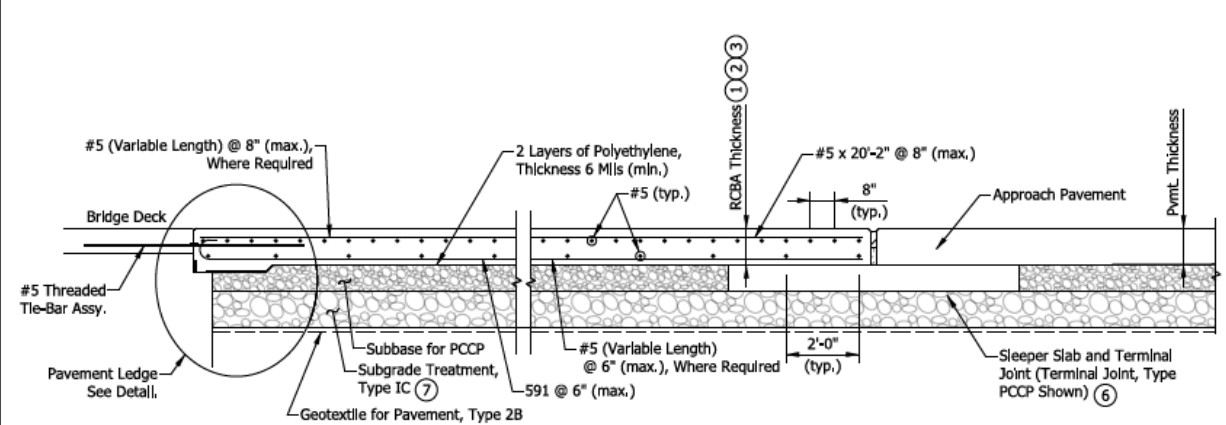

SECTION THROUGH APPROACH

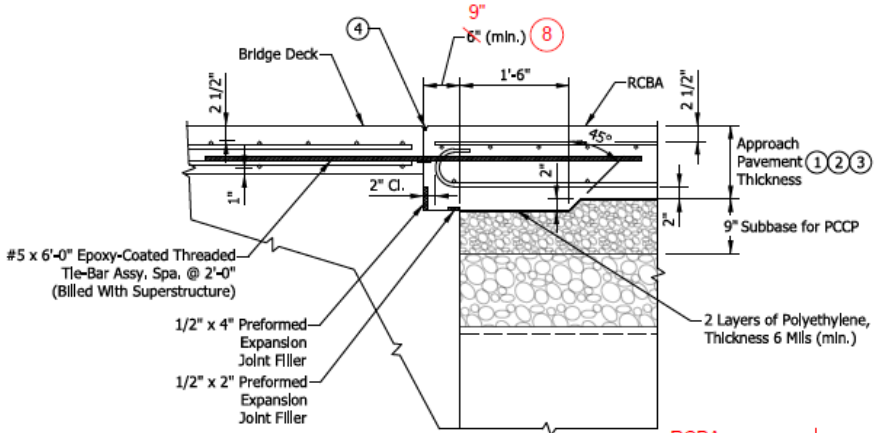

PAVEMENT LEDGE DETAIL



#5 x 6'-0" Epoxy-Coated Threaded Tie-Bar Assembly

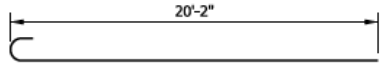

591 x 20'-9"

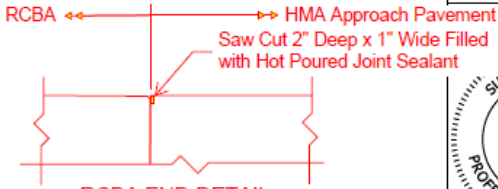

RCBA END DETAIL (ONLY APPLICABLE AT LOCATIONS WITHOUT TERMINAL JOINT)

NOTES:

- ① See plans for approach pavement thickness.
- ② For HMA approach pavement:
RCBA = 10 in. If design year AADT < 1000
RCBA = 12 in. If design year AADT ≥ 1000
- ③ For PCCP approach pavement:
RCBA = 12 in. If pavement thickness < 12 in.
RCBA = Same as pavement thickness, If pavement thickness ≥ 12 in.
- ④ See Standard Drawing series E 609-BRJT for joint type I-A details.
5. See Standard Drawing series E 703-BRST for reinforcing-bar bending details and notes.
- ⑥ When shown on the plans, see Standard Drawing series E 503-BATJ for terminal joint and sleeper slab details.
- ⑦ When the RCBA is constructed without a terminal joint, subgrade treatment shall be omitted and geotextile shall be placed under subbase for PCCP.
- ⑧ See plans for project specific pavement ledge dimensions.

INDIANA DEPARTMENT OF TRANSPORTATION
 REINFORCED CONCRETE BRIDGE APPROACH SECTION, PAVEMENT LEDGE, AND BAR BENDING DETAILS
 SEPTEMBER 2022

INDARD DRAWING NO. E 609-RCBA-04

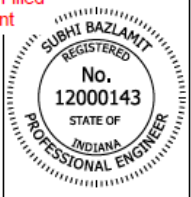

Subhi Bazlamit 6/15/2022
 DESIGN STANDARDS ENGINEER DATE
 06/27/2022
 CHIEF ENGINEER DATE

REVISION TO 2024 STANDARD DRAWINGS

E 609-RCBA-04 REINFORCED CONCRETE BRIDGE APPROACH SECTION, PAVEMENT LEDGE, AND BAR BENDING DETAILS (proposed draft)

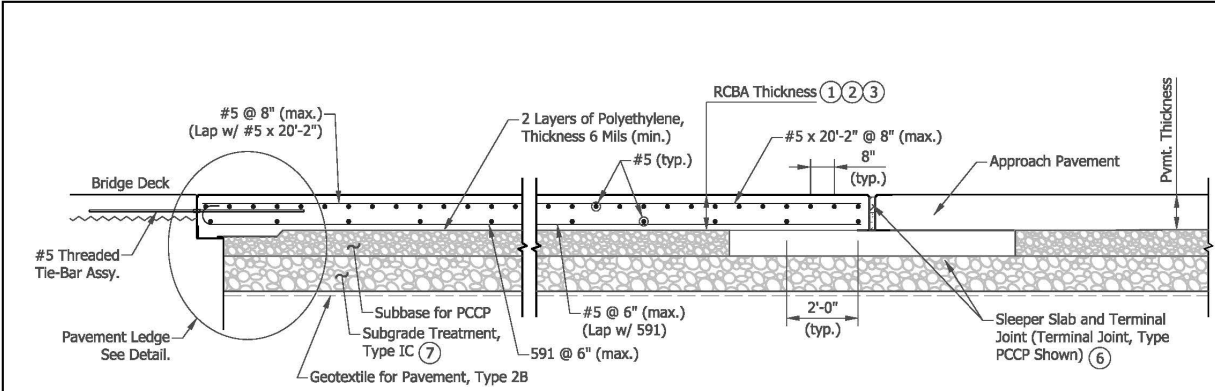

SECTION THROUGH APPROACH

NOTES:

- ① See plans for approach pavement thickness.
- ② For HMA approach pavement:
 RCBA = 10 in. if design year AADT < 1000
 RCBA = 12 in. if design year AADT ≥ 1000
- ③ For PCCP approach pavement:
 RCBA = 12 in. if pavement thickness < 12 in.
 RCBA = Same as pavement thickness, if pavement thickness ≥ 12 in.
- ④ See Standard Drawing series E 609-BRJT for joint type I-A details.
5. See Standard Drawing series E 703-BRST for reinforcing-bar bending details and notes.
- ⑥ When shown on the plans, see Standard Drawing series E 503-BATJ for terminal joint and sleeper slab details.
- ⑦ When the RCBA is constructed without a terminal joint, subgrade treatment shall be omitted and geotextile shall be placed under subbase for PCCP.
- ⑧ See plans for project specific pavement ledge dimensions.

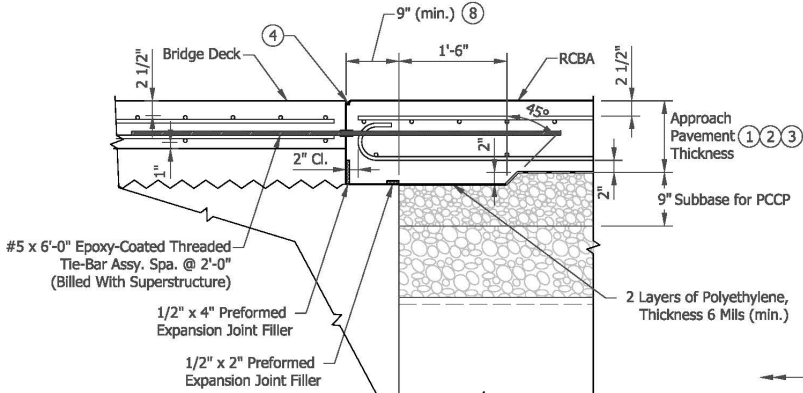

PAVEMENT LEDGE DETAIL

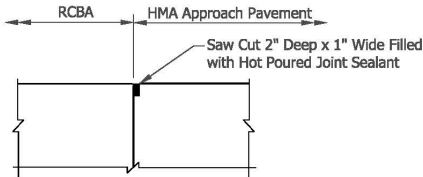

RCBA END DETAIL
 (ONLY APPLICABLE AT LOCATIONS WITHOUT TERMINAL JOINT)

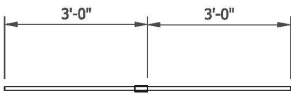

#5E x 6'-0" Epoxy-Coated Threaded Tie-Bar Assembly



#591 x 20'-9"

INDIANA DEPARTMENT OF TRANSPORTATION	
REINFORCED CONCRETE BRIDGE APPROACH SECTION, PAVEMENT LEDGE, AND BAR BENDING DETAILS	
SEPTEMBER 2025	
STANDARD DRAWING NO. E 609-RCBA-04	
DESIGN STANDARDS ENGINEER	DATE
CHIEF ENGINEER	DATE

COMMENTS AND ACTION

E 609-RCBA-04 REINFORCED CONCRETE BRIDGE APPROACH SECTION, PAVEMENT LEDGE, AND BAR BENDING DETAILS

DISCUSSION:

This item was introduced and presented by Mr. White, who stated that the current standard pavement ledge width of 6 in. can create vulnerabilities to future settlement of the RCBA relative to the bridge deck. The concrete-to-concrete bearing width is only 3 ½ in. after subtracting the widths of the PEJF material, so even a relatively small amount of deterioration or poor concrete consolidation can result in insufficient bearing capacity, which can lead to settlement. It has also been observed that the interface between the end of the RCBA and adjoining HMA pavement, when no terminal joint is required, can develop a slight separation that can allow water infiltration.

Mr. White proposed to increase the standard pavement ledge width from 6 in. to 9 in. and add a detail to seal the interface between the end of the RCBA and adjoining HMA pavement when no terminal joint is required.

Mr. Reilman asked how the joint between the RCBA and the adjoining HMA will be filled. Mr. White said it will be Hot Poured Joint Sealant as shown on the drawing. Mr. White said a RPD may be helpful until the revised standard drawing is effective.

There were no further comments or questions and this item passed as submitted.

<p>Motion: Mr. White Second: Mr. Koch Ayes: 10 Nays: 0 FHWA Approval: YES</p>	<p>Action:</p> <p><input checked="" type="checkbox"/> Passed as Submitted <input type="checkbox"/> Passed as Revised <input type="checkbox"/> Withdrawn</p>
<p>2024 Standard Specifications Sections: 609 begin pg. 520.</p>	<p><input type="checkbox"/> 2026 Standard Specifications <input type="checkbox"/> Revise Pay Items List <input type="checkbox"/> Notification to Designers if change is <u>not</u> addressed by RSP</p>
<p>Recurring Special Provisions or Plan Details: 609-B-311 & 609-B-322 (no changes required)</p>	<p><input type="checkbox"/> Create RSP (No. __) Effective:</p>
<p>Standard Drawing affected: E 609-RCBA-04</p>	<p><input type="checkbox"/> Revise RSP (No. __) Effective:</p>
<p>Design Manual Chapter: Several chapters in Section 4 contain figures that have been updated and will be published after the change to standards is approved.</p>	<p><input checked="" type="checkbox"/> Revise Standard Drawing (No. E 609-RCBA-04) Effective: September 1, 2025</p> <p><input checked="" type="checkbox"/> Create RPD (No. 609-B-323d) Effective: September 1, 2024</p>
<p>GIFE Section: N/A</p>	<p><input type="checkbox"/> GIFE Update <input type="checkbox"/> Frequency Manual Update <input type="checkbox"/> SiteManager Update</p>

PROPOSAL TO STANDARDS COMMITTEE

PROBLEM(S) ENCOUNTERED: Questions have arisen from the Contracts Division regarding the Basis for Use for RSP 203-B-025 Marion County Borrow Areas.

PROPOSED SOLUTION: Discontinue the use of the RSP, it is no longer needed. It has been in use since prior to 1987. A Marion County Master Plan Zoning Ordinance was amended in 1965 to establish Gravel/Sand/Borrow Districts. It allowed excavation in any zoning district for state highway contract work as part of a permit application process. However, the location of a project doesn't necessarily determine the location of the borrow pit, many counties (not just Marion) would have similar requirements, Std Spec 107.01 already covers this generally, and we have since implemented a robust IC-203 form as part of the approval process since this RSP was first created. Concurrence to discontinue was provided by the Indianapolis Dept. of Public Works.

APPLICABLE STANDARD SPECIFICATIONS: n/a

APPLICABLE STANDARD DRAWING: n/a

APPLICABLE DESIGN MANUAL CHAPTER: n/a

APPLICABLE SECTION OF GIFE: n/a

APPLICABLE RECURRING SPECIAL PROVISION OR PLAN DETAILS: RSP 203-B-025

PAY ITEMS AFFECTED: n/a

APPLICABLE SUB-COMMITTEE ENDORSEMENT: Ad hoc Sara Lamkin (Environmental Services), Joe Novak

IF APPROVED AS RECURRING SPECIAL PROVISION OR PLAN DETAILS, PROPOSED BASIS FOR USE: n/a

IMPACT ANALYSIS (attach report):

Submitted By: Joe Novak

Title: State Construction Engineer

Division: Construction Management

E-mail: jnovak@indot.in.gov

Date: 4/2/24

IMPACT ANALYSIS REPORT CHECKLIST

Explain the business case as to why this item should be presented to the Standards Committee for approval. Answer the following questions with Yes, No or N/A.

Does this item appear in any other specification sections? no

Will approval of this item affect the Qualified Products List (QPL)? no

Will this proposal improve:

Construction costs? no

Construction time? no

Customer satisfaction? no

Congestion/travel time? no

Ride quality? no

Will this proposal reduce operational costs or maintenance effort? no

Will this item improve safety:

For motorists? no

For construction workers? no

Will this proposal improve quality for:

Construction procedures/processes? no

Asset preservation? no

Design process? no

Will this change provide the contractor more flexibility? no

Will this proposal provide clarification for the Contractor and field personnel? no

Can this item improve/reduce the number of potential change orders? no

Is this proposal needed for compliance with:

Federal or State regulations? no

AASHTO or other design code? no

Is this item editorial? no

Provide any further information as to why this proposal should be placed on the Standards Committee meeting Agenda:

REVISION TO 2024 RECURRING SPECIAL PROVISION

203-B-025 MARION COUNTY BORROW AREAS (proposed to discontinue)

203-B-025 MARION COUNTY BORROW AREAS

(Revised 05-20-23)

The Standard Specifications are revised as follows:

SECTION 203, AFTER LINE 260, INSERT AS FOLLOWS:

Borrow areas in Marion County shall be in accordance with the applicable requirements of the Marion County Master Zone Plan with regard to the establishment of borrow areas and the production of sand and gravel as may be required.

FINAL DRAFT MINUTES

COMMENTS AND ACTION

203-B-025 MARION COUNTY BORROW AREAS

DISCUSSION:

This item was introduced and presented by Mr. Novak, who stated that questions have risen from the Contracts Division regarding the Basis for Use for RSP 203-B-025 Marion County Borrow Areas.

Mr. Novak proposed to discontinue the use of the RSP, which is no longer needed. It has been in use since prior to 1987. A Marion County Master Plan Zoning Ordinance was amended in 1965 to establish Gravel/Sand/Borrow Districts. It allowed excavation in any zoning district for state highway contract work as part of a permit application process. However, the location of a project doesn't necessarily determine the location of the borrow pit. Many counties (not just Marion) would have similar requirements, Standard Specification section 107.01 already covers this generally, and we have since implemented a robust IC-203 form as part of the approval process since this RSP was first created. Concurrence to discontinue was provided by the Indianapolis Dept. of Public Works.

There were no comments or questions and this item passed as submitted.

<p>Motion: Mr. Novak Second: Mr. Reilman Ayes: 10 Nays: 0 FHWA Approval: YES</p>	<p>Action: <input checked="" type="checkbox"/> Passed as Submitted <input type="checkbox"/> Passed as Revised <input type="checkbox"/> Withdrawn</p>
<p>2024 Standard Specifications Sections: 203 begin pg. 152.</p>	<p><input type="checkbox"/> 2026 Standard Specifications <input type="checkbox"/> Revise Pay Items List <input type="checkbox"/> Notification to Designers if change is <u>not</u> addressed by RSP</p>
<p>Recurring Special Provisions or Plan Details: 203-B-025 MARION COUNTY BORROW AREAS</p>	<p><input checked="" type="checkbox"/> Discontinue RSP (No. 203-B-025) Effective: September 1, 2024</p>
<p>Standard Drawing affected: NONE</p>	<p><input type="checkbox"/> Revise RSP (No. __) Effective:</p>
<p>Design Manual Chapter: NONE</p>	<p><input type="checkbox"/> Standard Drawing Effective:</p>
<p>GIFE Section: NONE</p>	<p><input type="checkbox"/> Create RPD (No. __) Effective:</p>
	<p><input type="checkbox"/> GIFE Update <input type="checkbox"/> Frequency Manual Update <input type="checkbox"/> SiteManager Update</p>

PROPOSAL TO STANDARDS COMMITTEE

PROBLEM(S) ENCOUNTERED: The *Standard Specifications* currently don't provide requirements for maximum spacing of support devices or spacers used to support reinforcing bars. The Department has recently observed honeycombing on the underside of reinforced concrete slabs, and ground penetrating radar, GPR, results indicating top cover thickness which varied significantly from plan. These are indications that the spacing of support devices may have been too large, resulting in displacement of the reinforcing bars during the placement of concrete.

PROPOSED SOLUTION: Revise section 703 to provide an upper limit on the spacing of support devices, and explicitly allow bent reinforcing bars to be used as support devices.

APPLICABLE STANDARD SPECIFICATIONS: 703.06, 703.08

APPLICABLE STANDARD DRAWING: N/A

APPLICABLE DESIGN MANUAL CHAPTER: 405 (will be updated upon approval of specification change)

APPLICABLE SECTION OF GIFE: 5.12 (no changes anticipated)

APPLICABLE RECURRING SPECIAL PROVISION OR PLAN DETAILS: N/A

PAY ITEMS AFFECTED: N/A

APPLICABLE SUB-COMMITTEE ENDORSEMENT: Ad hoc committee including Mike Nelson, Andrew Pinkstaff, and Jim Reilman.

IF APPROVED AS RECURRING SPECIAL PROVISION OR PLAN DETAILS, PROPOSED BASIS FOR USE:
All contracts that include 703 pay items

IMPACT ANALYSIS (attach report):

Submitted By: Pete White

Title: Design Manager

Division: INDOT Bridge Engineering

E-mail: pewwhite@indot.in.gov

Date: April 5, 2024

IMPACT ANALYSIS REPORT CHECKLIST

*Explain the business case as to why this item should be presented to the Standards Committee for approval.
Answer the following questions with Yes, No or N/A.*

Does this item appear in any other specification sections? No

Will approval of this item affect the Qualified Products List (QPL)? No

Will this proposal improve:

Construction costs? No

Construction time? No

Customer satisfaction? No

Congestion/travel time? No

Ride quality? No

Will this proposal reduce operational costs or maintenance effort? Yes

Will this item improve safety:

For motorists? No

For construction workers? No

Will this proposal improve quality for:

Construction procedures/processes? Yes

Asset preservation? Yes

Design process? Yes

Will this change provide the contractor more flexibility? Yes

Will this proposal provide clarification for the Contractor and field personnel? Yes

Can this item improve/reduce the number of potential change orders? No

Is this proposal needed for compliance with:

Federal or State regulations? No

AASHTO or other design code? No

Is this item editorial? No

Provide any further information as to why this proposal should be placed on the
Standards Committee meeting Agenda:

REVISION TO 2024 STANDARD SPECIFICATIONS

SECTION 703 – REINFORCING BARS
703.06 Placing and Fastening
703.08 Basis of Payment

(Note: Proposed changes shown highlighted gray)

The Standard Specifications are revised as follows:

SECTION 703, BEGIN LINE 52, DELETE AND INSERT AS FOLLOWS:

703.06 Placing and Fastening

Reinforcing bars shall not be ordered for piers or bents to be founded on soil or rock until the foundation conditions have been investigated. The bottom elevations of such footings will then be determined. Written permission will then be given to order such reinforcing bars. Sufficient excavation and all necessary soundings shall be made as directed so that exact bottom elevations of footings may be determined.

All dimensions shown on the plans for spacing of reinforcing bars apply to centers of bars unless otherwise noted. All bars shall be accurately placed and, during placing of the concrete, held firmly in the position as shown on the plans. Distances from the forms shall be maintained by means of chairs, ties, hangers, or other approved support devices. All reinforcing bars shall be wired rigidly or fastened securely at sufficient intervals to hold the bars in place. *Welding of reinforcing bars shall will not be performed allowed.* Epoxy coated reinforcing bars shall be tied with epoxy coated or plastic coated tie wire. ~~Chairs and supports holding upper layers of reinforcing bars shall support the transverse bars.~~ The upper layer and lower layer of reinforcing bars in RCBA's and bridge floors shall be tied or fastened at a minimum of every other intersection of the longitudinal and transverse bars to prevent an upward or a lateral movement of a bar from the planned position.

Layers of reinforcing bars shall be separated by ~~spacers~~ *support devices in accordance with 910.01(b)11 or epoxy coated reinforcing bars. Epoxy coated reinforcing bars used to separate and support layers of reinforcing bars shall be shop bent to the dimensions required to secure the layers of reinforcing bars in the positions shown on the plans. The size and spacing of support devices or epoxy coated reinforcing bars used as supports shall be such that the plan reinforcing bars are not displaced by the weight of concrete, upper layers of reinforcing bars, or construction loads, but in no case shall the spacing exceed 3 ft in any direction.* Reinforcing bars shall be separated from horizontal surfaces by being suspended or supported on approved ~~chairs and spacers~~ *support devices* capable of supporting the designed loads. Supports and spacers shall be of such shape as to be easily encased in concrete. That portion which is in contact with the forms shall be non-corrosive and non-staining material. They shall be of an approved type. ~~Vertical stirrups shall always pass around main tension members and shall be securely attached thereto.~~ The use of pebbles, pieces of broken stone or bricks, metal pipe, wooden blocks, and similar devices for holding bars in position will not be allowed.

SECTION 703, BEGIN LINE 132, DELETE AND INSERT AS FOLLOWS:

703.08 Basis of Payment

The accepted quantities of reinforcing bars will be paid for at the contract price per pound, complete in place.

REVISION TO 2024 STANDARD SPECIFICATIONS

SECTION 703 – REINFORCING BARS
703.06 Placing and Fastening
703.08 Basis of Payment

If the substitution of reinforcing bars larger than those specified is allowed, payment will be made for only that weight which would be required if the specified bars had been used.

If the use of reinforcing bar lengths shorter than those shown on the plans is allowed for convenience in transporting or placing the bars, payment will be based on the weight of the lengths shown on the plans.

Payment for threaded tie bar assemblies will be at the contract unit price per each, complete in place. If epoxy coating is specified, payment for the assemblies will be at the contract unit price per each for threaded tie bar assembly, epoxy coated.

Payment will be made under:

Pay Item	Pay Unit Symbol
Reinforcing Bars	LBS
Reinforcing Bars, Epoxy Coated	LBS
Threaded Tie Bar Assembly	EACH
Threaded Tie Bar Assembly, Epoxy Coated	EACH

The cost of ~~metal chairs~~ *support devices or epoxy coated reinforcing bars used as supports*, spacers, clips, wire, or other mechanical means used for fastening or holding reinforcement in place, and laps shall be included in the cost of reinforcing bars. The cost of coating materials and repair of damaged or removed coating materials on reinforcing bars and on metal chairs, spacers, clips, or other mechanical means used for fastening or holding reinforcement in place, and laps shall be included in the cost of epoxy coated reinforcing bars. If threaded tie bar assemblies are used in lieu of spliced reinforcing bars as shown on the plans, the cost of such assemblies shall be included in the cost of reinforcing bars.

If WWR is required, the cost of furnishing and placing shall be included in the cost of the concrete in which it is placed.

COMMENTS AND ACTION

703.06 Placing and Fastening
703.08 Basis of Payment

DISCUSSION:

Mr. White introduced and presented this item stating that the Standard Specifications currently don't provide requirements for maximum spacing of support devices or spacers used to support reinforcing bars. The Department has recently observed honeycombing on the underside of reinforced concrete slabs, and ground penetrating radar, GPR, results indicating top cover thickness which varied significantly from plan. These are indications that the spacing of support devices may have been too large, resulting in displacement of the reinforcing bars during the placement of concrete.

Mr. White proposed to withdraw this item pending further review with ICI and industry.

Mr. Duncan, FHWA, asked about the line concerning Vertical Stirrups being struck. Mr. White explained that the information is shown on the standard drawings, so having that language in 703.06 is not necessary. Mr. Duncan concurred.

<p>Motion: Second: Ayes: Nays: FHWA Approval:</p>	<p>Action: <input type="checkbox"/> Passed as Submitted <input type="checkbox"/> Passed as Revised <input checked="" type="checkbox"/> Withdrawn</p>
<p>2024 Standard Specifications Sections: 703.06 pg. 650 and 703.08 pg. 652.</p> <p>Recurring Special Provisions or Plan Details: NONE</p> <p>Standard Drawing affected: N/A</p> <p>Design Manual Chapter: 405 (will be updated upon approval of specification change)</p> <p>GIFE Section: 5.12 (no changes anticipated)</p>	<p><input type="checkbox"/> 2026 Standard Specifications <input type="checkbox"/> Revise Pay Items List <input type="checkbox"/> Notification to Designers if change is <u>not</u> addressed by RSP</p> <p><input type="checkbox"/> Create RSP (No. __) Effective:</p> <p><input type="checkbox"/> Revise RSP (No. __) Effective:</p> <p><input type="checkbox"/> Standard Drawing Effective:</p> <p><input type="checkbox"/> Create RPD (No. __) Effective:</p> <p><input type="checkbox"/> GIFE Update <input type="checkbox"/> Frequency Manual Update <input type="checkbox"/> SiteManager Update</p>